

- NOTE:**
1. All welding done per AWS Specification
 2. All parts are Hot Dipped Galvanized after fabrication (except allthreads & locknuts)
 3. All allthreads and locknuts zinc plated and threads coated with anti-seize.
 4. Contractor to confirm required height of stand.

This Drawing to be signed and returned to Placer Waterworks Inc. before fabrication is started.

X _____

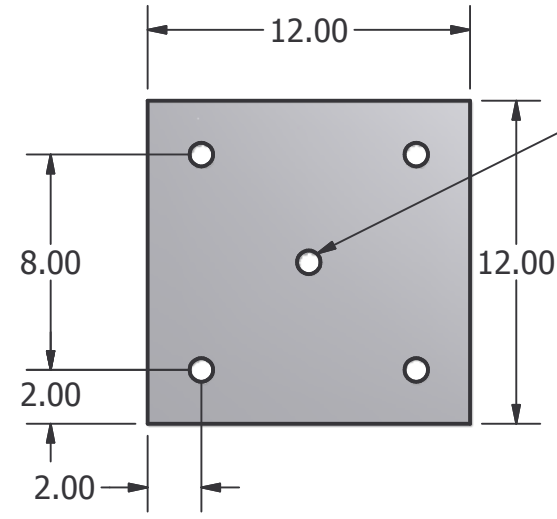

DRAWN Gary	12/12/2008	Placer Waterworks (530) 742-9675		
CHECKED				
QA		TITLE		
MFG		8" & 12" Bolt To Flange Saddle & Stands		
APPROVED		SIZE B	DWG NO Stand and Bolt to Flg Saddle	REV
		SCALE	1 1	